

1

2

3

4

A

B

C

D

E

F

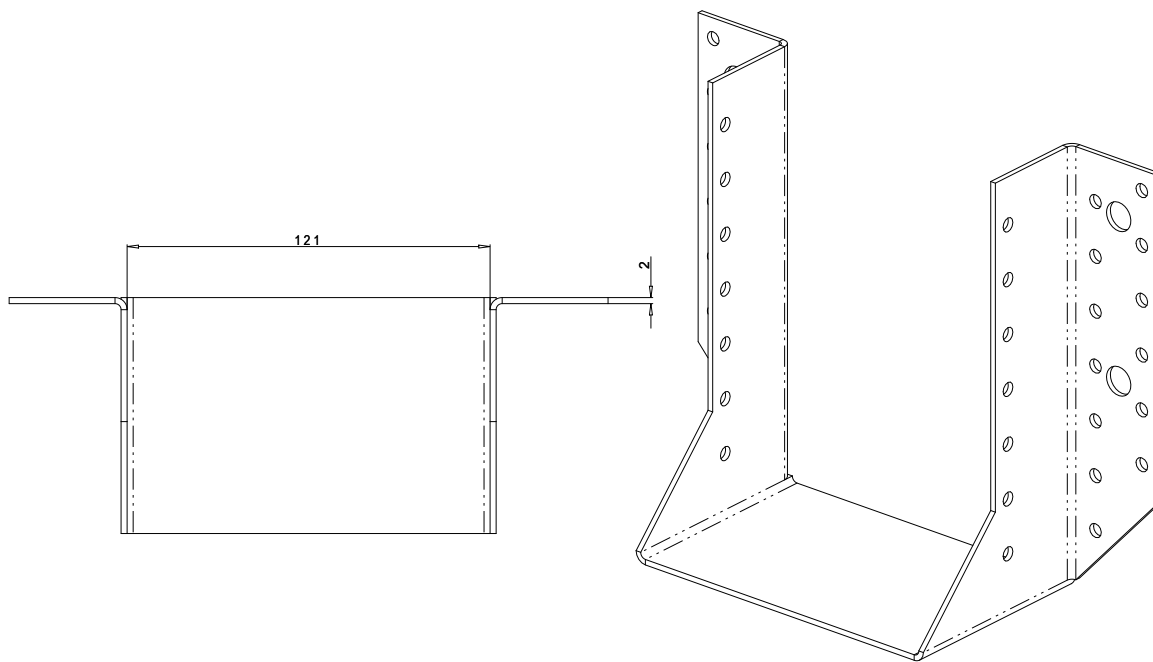
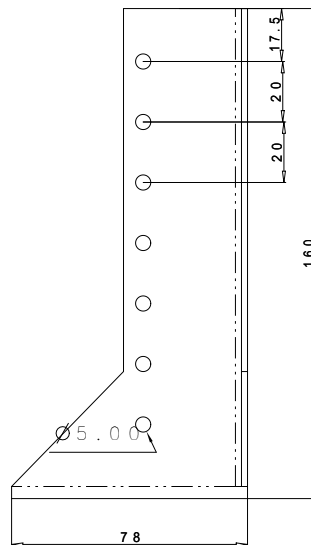
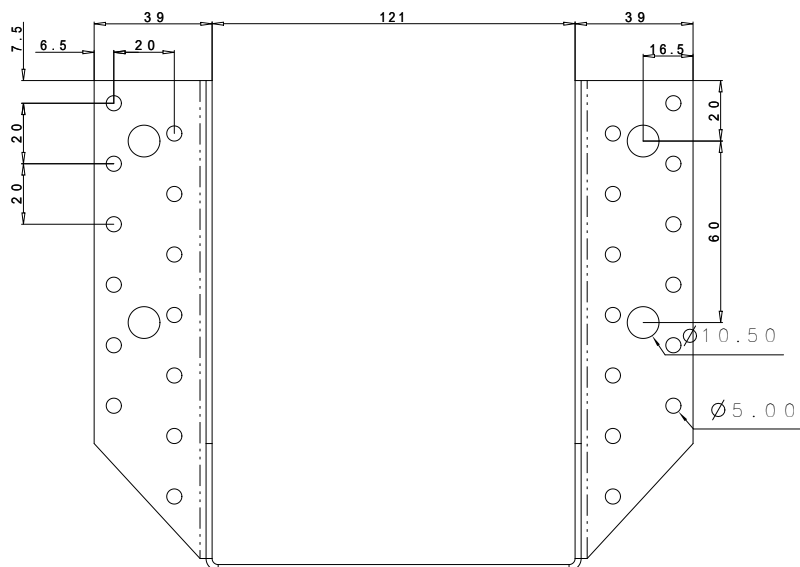

TOLLERANZE GENERALI GENERAL TOLERANCE	0<...<3	3<...<6	6<...<10	10<...<18	18<...<30	30<...<50	50<...<80	80<...<120	120<...<180	180<...<250	250<...<500	500<...<2000
LUNGHEZZE LENGTHS	±0.15	±0.20	±0.25	±0.30	±0.35	±0.40	±0.45	±0.50	±0.60	±0.70	±0.80	/
ANGOLI ANGLES	0°<...<10° ±0.50°			10°<...<45° ±1°			45°<...<90° ±1.50°			90°<...<360° ±2°		
MOD.	DESCRIZIONE DESCRIPTION						DISEGNATO DESIGNER	APPROVATO APPROVED	DATA DATE			
UNIT: mm EUROPEAN VIEW 	S.R.L. <b>Advenco</b> Via Monte Gaglielmo 61, 25060 COGOZZO di Villa Carcina (Brescia), Italy Tel. +39 030 800916 - Fax +39 030 802172 www.advenco.com						APPROVATO APPROVED	MORETTI A.	01/10/2021			
DENOMINAZIONE	Scarpa ancoraggio travetti tipo V 120x160						DISEGNATO DRAWN	REALI S.	01/10/2021			
PART NAME							SCALA SCALE	REV. 0				
PESO 100 PEZZI TOLL. 10% WEIGHT 100 PIECES TOLL. 10%	LAVORAZIONE LABORATION	SPESORE 2.00mm/THICKNESS 2.00mm					TRATTAMENTO T. T. TREATMENT					
TOLLERANZA GENERALE FORI: ±0.3 HOLES GENERAL TOLERANCE: ±0.3	MATERIALE MATERIAL	Acciaio / Steel					TRATTAMENTO SUP. SURF. TREATMENT	ZINCATURA/GALVANIZATION				
E' VIETATA LA RIPRODUZIONE ANCHE PARZIALE DEL PRESENTE DISEGNO SENZA L'AUTORIZZAZIONE DI ADVENCO S.R.L./IT IS FORBIDDEN THE REPRODUCTION, PARCIAL TOO, OF THIS DRAWING WHITOUT THE ADVENCO WRITTEN AUTORIZAZION											FORMATO FORMAT	A 4